

Connex500/350 3D Printer Site Preparation Guide

DOC-13001

Rev. L1



Copyright

Copyright © 2015 Stratasys Ltd. All rights reserved.

This documentation contains proprietary information of Stratasys Ltd. This information is supplied solely to assist authorized users of this Stratasys 3D printing system. No part of this document may be used for other purposes, and it may not be disclosed to other parties.

The specifications on which this document is based are subject to change without notice.

No part of this book may be reproduced in any form or by any means, nor stored in a database or retrieval system, without prior permission in writing from Stratasys Ltd.

If this document is distributed as a PDF file, you may print it for internal use.

July 2015

DOC-13001 Rev. L1

Trademarks

The following are registered trademarks of Stratasys Ltd.: Stratasys®, Objet®, FullCure®.

All names of products and services cited in this book are trademarks or registered trademarks of their respective companies.

Contents

1 Introduction	4
2 Physical Description	5
2.1 Configuration	5
2.2 Size and Weight	5
3 Shipment and Delivery	6
3.1 Shipping Information and Customer Responsibility	6
3.2 Shipping Pallet	6
3.3 Lifting Equipment	6
3.4 Unloading	6
4 Installation Area	7
4.1 Floor Plan (Printer Area)	8
5 Workstation Requirements	9
6 Electrical Requirements	10
6.1 Power	10
6.2 Circuit Breaker	10
6.3 Grounding	10
6.4 Residual Current Device (RCD)	10
6.5 Printer Connection	11
6.6 UPS (Uninterrupted Power Supply)	11
7 Communication Lines	12
7.1 Local Area Network	12
7.2 Telephone	12
8 Environmental Conditions	13
8.1 Temperature and Humidity	13
8.2 Ventilation	13
8.3 Noise Level	13
9 Accessories and Utilities	14
9.1 Start-Up Kit	14
9.2 Exhaust Adapter	14
9.3 Eyewash Station	15
9.4 Compressed Air	15
9.5 Fire Safety Equipment	15
10 Materials Handling and Storage	16
10.1 Printing Materials	16
10.2 Cleaning Solvent	16
11 Summary	17
11.1 Customer Information	17
11.2 Site Preparation Checklist	17

1 Introduction

The information and requirements provided in this document ensure proper installation and operation of the Connex500/350 3D printing system. The customer is responsible for preparing the site as described in this document.

If you have any questions about the information in this document, contact your Stratasys representative.

All site requirements must be met before the installation date. The Site Preparation Checklist should be faxed to your Stratasys representative. Shipping will be arranged after the signed checklist is received by Stratasys.

Non-compliance with requirements specified in this document may result in additional installation charges.

2 Physical Description

2.1 Configuration

The Connex500/350 3D printing system consists of the following main components:

- The printer
- The printer computer (built into the printer)
- A printer-server workstation (computer provided by the customer)



Figure 1 Connex500 printer

2.2 Size and Weight

The following table shows the size and weight information for Connex printers.

Table 1 Printer size and weight

Unit	W × H × D (cm)	W × H × D (inch)	Weight (kg/lb)
Connex500/350	142 × 112 × 113	56 × 44.5 × 44	500 kg / 1100 lb



W = Width; H = Height; D = Depth.

3 Shipment and Delivery

3.1 Shipping Information and Customer Responsibility

Shipment to the customer will be arranged by a Stratasys distributor as indicated in the “ship to” part of the invoice. The customer is responsible for providing detailed delivery instructions.

The customer is responsible for transporting the printer to a suitable installation site.

Upon request, customer support engineers will provide advice regarding these matters.



Only customer support engineers are authorized to unpack and install equipment.

3.2 Shipping Pallet

The printer arrives on a wooden pallet. The following table shows the approximate size and weight of the printer mounted on the pallet.

Table 2 Size and weight of printer on shipping pallet

W × H × D (cm)	W × H × D (inch)	Weight (kg/lb)
165 × 130 × 140	65 × 51.2 × 55.1	580 kg / 1276 lb

3.3 Lifting Equipment

A forklift or hand pallet truck with the following specifications is required:

- Lifting capacity of 800 kg (1650 lb)
- 150-centimeter (60-inch) extension

3.4 Unloading

The type of truck required to deliver the printer depends on whether a loading dock is available at the delivery site.

The unloading area should be a level surface.

- A receiving area of 10 m² (108 sq ft) is required for the forklift to remove the printer from the delivery truck.
- A clearance of 120 cm (4 ft) around the back and sides of the packaging for unpacking the printer.
- A clearance of 390 cm (13 ft) from the front is required for unloading the printer from the pallet.

The installation location must be accessible from the unloading area. The customer is responsible for unloading the printer from the truck and transferring it to the installation location.

4 Installation Area

The installation area should meet the following conditions:

- The installation area should be free of sources of vibration and electromagnetic interference that could affect the proper functioning of the printer.
- The floor gradient should be less than 0.5% (no more than 5 mm per meter).
- The floor should be stable and able to bear the load of the printer. The minimum floor load is 607 kg/m² (125 lb/ft²).
- The server workstation and the printer should be located in the same room.
- The cable route between the server workstation and the printer should not exceed 5 meters (16 feet).



The communication cable provided should not be extended or replaced with a longer cable.

- Clearance around and above the printer should ensure convenient access and servicing.
- The area around the printer should be dry at all times. Do not place the WaterJet cleaning station within 5 meters (16 feet) of the printer.
- Shelves and cabinets should be located near the printer to allow convenient storage of tools, parts, accessories, manuals, and materials (see section 10).

4.1 Floor Plan (Printer Area)

The following is a sample floor plan, showing the 3D printing system—the printer and the server workstation. The dimensions shown in the figure are the minimum clearance requirements.

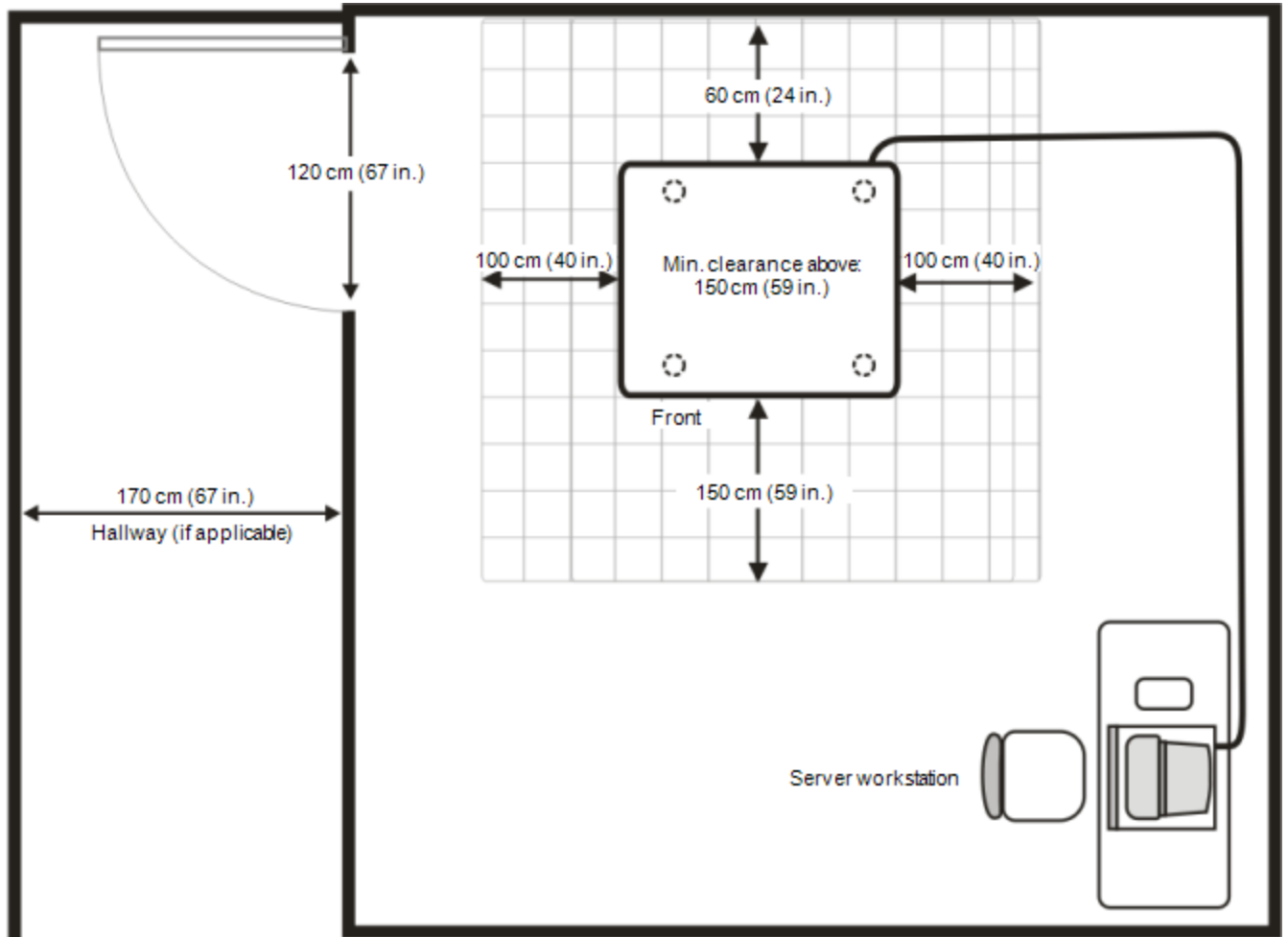

Figure 2 Printer floor plan sample (not to scale)

5 Workstation Requirements

The customer is responsible for supplying a computer, with the following specifications, for the server workstation. The same specifications are recommended for any additional client workstations.



Make sure that the server workstation is set up with Administrator privileges.

	Requirement
Computer Type	Server workstation: Standard desktop PC ¹
Processor	Intel® Core™ i3 or better
Operating System	Windows® 7 64-bit or Windows® 8 64-bit ²
RAM	8 GB or more
Graphics Card ³	Open GL® Memory: 1 GB or more; 2 GB recommended for dental applications
	For server workstation: VGA connector ⁴
Optical Drive	CD/DVD ROM
HDD/SSD	80 GB or larger (minimum free space of 40 GB)
Network Card	LAN TCP/IP (2 network cards for server workstation; 1 network card for client workstation)
Mouse/Keyboard Connection	Server workstation: USB
Monitor Cable	VGA connector
Anti-virus ⁵	Tested: TrendMicro, Eset NOD32, AVG, Kaspersky

¹ For systems using a KVM switch box to control both the built-in printer computer and the server workstation with same keyboard-monitor-mouse set: All-in-one computer, wireless mouse and wireless keyboard cannot be used.

² A 64-bit operating system is recommended, to utilize 8 GB of memory.

Objet Studio running on a 32-bit application can utilize only 4 GB of memory.

³ The following graphics cards were also tested in Stratasys labs:

- NVIDIA® Quadro® Family—FX570, FX1700
- NVIDIA® GeForce® Family—6200 TurboCache™, 7300 GT, GTX 285
- Intel® Express Chipset—82915G/GV, 82910GL, Q965, Q963, Q35, Q45, Q43, 82852, 82855
- ATI Radeon™ HD 5670, HD 5970
- AMD Radeon™ E6760

⁴ For systems using a KVM switch box. If the server workstation has a DVI video connector, a VGA adapter is needed.

⁵ Most anti-virus programs can be used with the server workstation. Programs by vendors listed were tested in Stratasys labs.

6 Electrical Requirements

The customer is responsible for ensuring that all tasks described in this section are carried out by qualified personnel.

6.1 Power

A stable, reliable source of power is required. Power to the UPS should be supplied directly from the main electrical panel. The line should not be connected to other electrical outlets.

- 100–120 VAC, 50–60 Hz, 13.5 A , 1 phase
- 220–240 VAC, 50–60 Hz, 7 A , 1 phase

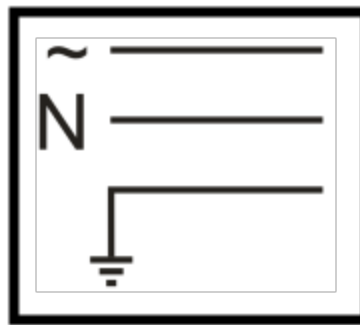

Figure 3 Wiring diagram

6.2 Circuit Breaker

A Type-C circuit breaker with the following specification is required on the power line (subject to the local electrical code).

The following table lists the requirements for the circuit breaker.

Table 3 Circuit breaker

Voltage	Circuit Breaker
100–120 VAC	15 A or 16 A
220–240 VAC	10 A

6.3 Grounding

The printer is grounded through a single-phase, AC plug. Make sure that the AC outlet is properly grounded, in accordance with local electrical codes.

6.4 Residual Current Device (RCD)

The wall outlet must be connected to a residual current device (RCD)—also known as a ground current-leakage detector—that protects the circuit from a current leakage of more than 30 mA.

6.5 Printer Connection

The printer is shipped with the following cables:

- 220-VAC cable. The customer must provide an appropriate power plug and have it installed by an electrician.
- 110-VAC cable, including a power plug

The following electrical outlets are required:

- one outlet behind the printer
- three outlets close to the printer (for the workstation, monitor, and servicing equipment)

6.6 UPS (Uninterrupted Power Supply)

It is recommended that the printer be powered from a UPS. A UPS ensures that—

- the quality of printing is not affected by power fluctuations from the mains.
- the printer can be programmed to perform “graceful shutdown” in the event of a power failure. This is possible with some UPSs, such as the third-party Eaton PW9130L2000T-XL.

It is the customer’s responsibility to order the UPS.

Table 4 UPS requirements

Voltage ¹	Current	Power	Power Factor ²	Bridging Time	Interface
100–120 VAC	16 Amps	1500 VA	0.9	15 minutes	USB port ³
220–240 VAC	8 Amps				

The third-party Eaton PW9130L2000T-XL UPS has been tested at Stratasys and has been found to meet the above requirements.

¹Single-phase; 50/60 Hz

²Defined as the input-to-output ratio of the UPS.

³Do not order a UPS that only has a serial communications-port connector.

7 Communication Lines

7.1 Local Area Network

A LAN communication cable is required if server/client workstations are connected to a local network, as shown in the following diagram.

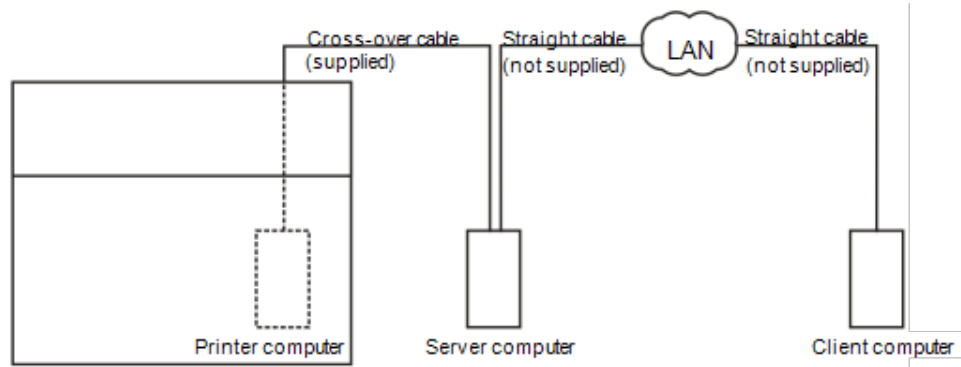

Figure 4 Network installation

The connection to the local network should be done *before* printer installation.

7.2 Telephone

A telephone line for general communication and service calls is recommended, near the printer.

8 Environmental Conditions

8.1 Temperature and Humidity

The temperature and relative humidity around the printer must be within certain limits. Peak conditions occur when the printer and the server workstation draw maximum electrical power, resulting in the heat dissipation listed in the table below.

Table 5 Heat dissipation (peak conditions)

	Heat Dissipation
Printer	1500 W (5140 BTU/hr)
Server workstation	450 W (1530 BTU/hr)
Total	1950 W (6670 BTU/hr)

Environmental control should ensure that the room temperature and relative humidity do not exceed the limits listed in the table below.

Table 6 Room temperature and relative humidity

	Range
Temperature	18° C to 25° C (64.5° F to 77° F)
Relative humidity	30%–70% non-condensing

8.2 Ventilation

To ensure optimal air quality around the printer, a connection to an external ventilation duct is recommended. Otherwise, the room ventilation system should change the air at least four times every hour. If an exhaust fan on an external wall is used, it should be located near the back of the printer.

8.3 Noise Level

The noise level around the printer is typically less than 65 dB during printing.

9 Accessories and Utilities

9.1 Start-Up Kit

A start-up kit, purchased separately, includes tools and accessories that are essential for the installation and proper operation of the printer. Make sure that this kit is available during printer installation.

9.2 Exhaust Adapter

An exhaust adapter is supplied with the printer. When attached to the back of the printer and connected to an external ventilation fan with a duct, air expelled from the printer is discharged directly outdoors, as shown in the figure below.

Tube Diameter	Required Suction	
	Minimum	Maximum
4 in (100 mm)	212 cfm (6 m ³ /min)	269 cfm (7.6 m ³ /min)

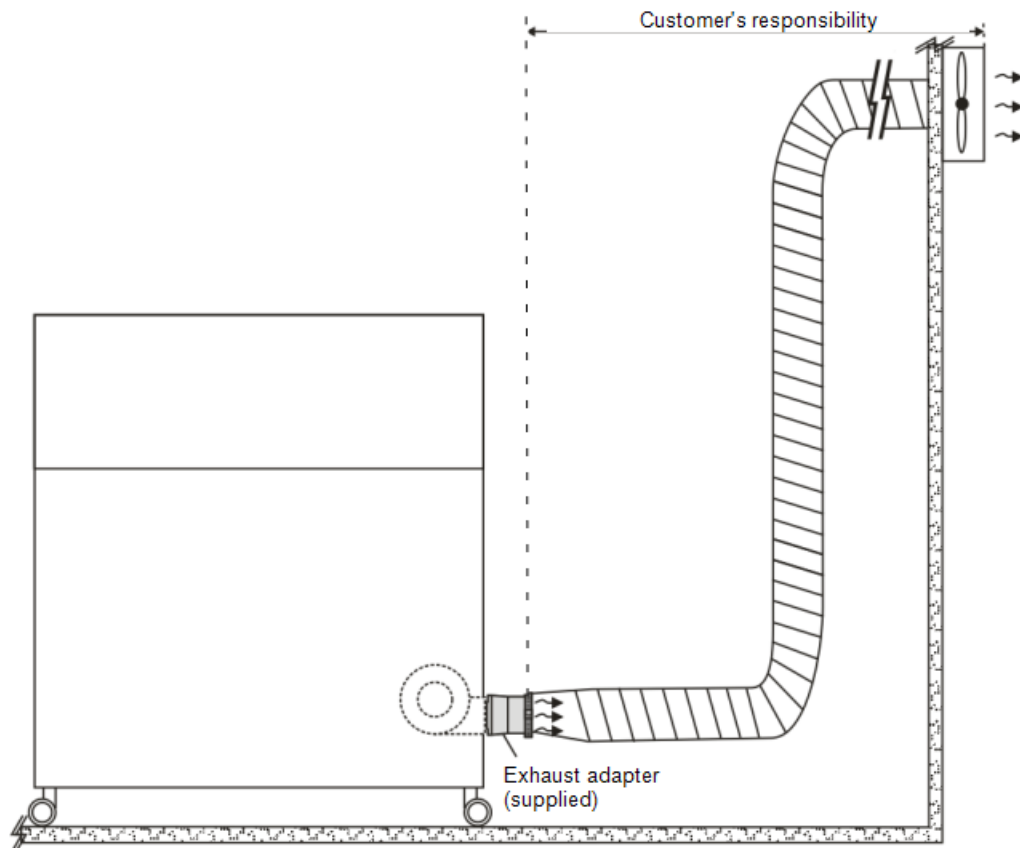

Figure 5 Printer exhaust system

9.3 Eyewash Station

It is recommended to install an eyewash station near the printer.

9.4 Compressed Air

Compressed air is useful for routine cleaning and maintenance activities. If a compressed air line is available at the site, it is recommended (but not required) that an outlet be installed near the printer.



If the compressed air line does not include an air-dryer unit, a water/oil trap must be installed on the air gun used for cleaning the printer. The recommended air pressure is 5–6 bar (70–90 psi).

9.5 Fire Safety Equipment

A gas-based fire extinguisher is recommended in case of fire in or near the system. Some other fire extinguishers are also acceptable, but liquid fire extinguishers should not be used. (Contact local fire authorities for specific recommendations.)

10 Materials Handling and Storage

10.1 Printing Materials

Printing materials should be stored indoors, in a dry area with adequate ventilation. The following table lists general requirements for transport, storage, inventory control, and disposal.

Table 7 Requirements for hazardous materials

Topic	Requirement
Storage	15°C to 25°C (60°F to 81°F)
Inventory control method	First In First Out (FIFO)
Disposal	In compliance with local regulations

These specifications are applicable for most printing materials. Requirements for handling and storing specific materials appear in the Material Safety Datasheet (MSDS) included with each material.

Printing materials can be used until the expiration date indicated on the container. Inventory provisions should be made to ensure that containers with the closest expiry date are used first.

When a material container is not in use, it should be securely capped, to protect the material from contamination and UV radiation. In addition, this minimizes the risk of accidental spillage.



- Non-compliance with these recommendations might result in reduced shelf life.
- Disposal of all liquid and solid waste, cleaning cloths, gloves, and empty material containers must be done in accordance with local laws and regulations.

10.2 Cleaning Solvent

One liter of isopropanol (IPA) or ethanol (ethyl alcohol) should be available at all times for cleaning purposes.

Solvents should be stored and handled in accordance with local regulations.

11 Summary

Dear customer,

Please fill in the information requested below, and fax it to your Stratasys representative. An installation date will be scheduled after this checklist is approved by Stratasys.

Consult with a Stratasys-certified engineer if you have any questions about the site requirements and the checklist.

11.1 Customer Information

Company Name: _____

Address: _____

Phone No.: _____ Fax No.: _____

E-mail: _____

11.2 Site Preparation Checklist

Item and reference	Meets Requirement		Notes
	Yes	No	
Personnel available for training	<input type="checkbox"/>	<input type="checkbox"/>	
Forklift and unloading area	<input type="checkbox"/>	<input type="checkbox"/>	
Floor requirements	<input type="checkbox"/>	<input type="checkbox"/>	
Room layout (printer)	<input type="checkbox"/>	<input type="checkbox"/>	
Access to installation location: doors, hallways, etc.	<input type="checkbox"/>	<input type="checkbox"/>	
Power requirements	<input type="checkbox"/>	<input type="checkbox"/>	
Circuit breaker	<input type="checkbox"/>	<input type="checkbox"/>	
Grounding protection	<input type="checkbox"/>	<input type="checkbox"/>	
Power plug	<input type="checkbox"/>	<input type="checkbox"/>	
UPS unit	<input type="checkbox"/>	<input type="checkbox"/>	
Server workstation with two network cards	<input type="checkbox"/>	<input type="checkbox"/>	
Communication lines	<input type="checkbox"/>	<input type="checkbox"/>	
Environmental conditions	<input type="checkbox"/>	<input type="checkbox"/>	
Ventilation	<input type="checkbox"/>	<input type="checkbox"/>	
Fire extinguisher	<input type="checkbox"/>	<input type="checkbox"/>	
Cleaning solvent	<input type="checkbox"/>	<input type="checkbox"/>	

I understand that non-compliance with the requirements specified in this document may result in additional installation charges.

Full name: _____

Customer's signature: _____ Date: _____