

# Site Preparation Guide



# stratasys®

Stratasys J750/J700

3D Printing System



## Copyright

Copyright © 2017 Stratasys Ltd. All rights reserved.

This documentation contains proprietary information of Stratasys Ltd. This information is supplied solely to assist authorized users of this Stratasys 3D printing system. No part of this document may be used for other purposes, and it may not be disclosed to other parties.

The specifications on which this document is based are subject to change without notice.

No part of this book may be reproduced in any form or by any means, nor stored in a database or retrieval system, without prior permission in writing from Stratasys Ltd.

If this document is distributed as a PDF file, you may print it for internal use.

October 2017

DOC-08032 Rev. A2

## Trademarks

The following are registered trademarks of Stratasys Ltd.: Stratasys<sup>®</sup>, Objet<sup>®</sup>, FullCure<sup>®</sup>.

All names of products and services cited in this book are trademarks or registered trademarks of their respective companies.

# Contents

---

<b>Introduction</b> .....	<b>5</b>
About this Guide .....	5
Installation and Training Schedule .....	5
<b>Physical Description</b> .....	<b>6</b>
Size and Weight .....	6
<b>Shipment and Delivery</b> .....	<b>7</b>
Shipping Information and Customer Responsibility .....	7
Shipping Pallet .....	7
Lifting Equipment .....	7
Unloading .....	8
<b>Installation Area</b> .....	<b>9</b>
Floor Plan (Printer Area) .....	9
<b>Workstation Requirements</b> .....	<b>10</b>
<b>Electrical Requirements</b> .....	<b>11</b>
Power .....	11
Grounding .....	11
Circuit Breaker .....	12
Residual Current Device (RCD) .....	12
Power Connection .....	12
UPS (Uninterrupted Power Supply) .....	12
<b>Communication Lines</b> .....	<b>14</b>
Local Area Network .....	14
Telephone .....	14
<b>Environmental Conditions</b> .....	<b>15</b>
Temperature and Humidity .....	15
Air Quality .....	15
Noise Level .....	15
<b>Accessories and Utilities</b> .....	<b>16</b>
Start-Up Kit .....	16
Exhaust Adapter .....	16
Eyewash Station .....	16
Compressed Air .....	17
Fire Safety Equipment .....	17

Materials Handling and Storage .....	18
Printing Materials .....	18
Cleaning Solvent .....	18
Site Preparation Checklist .....	19

# Introduction

## About this Guide

The information and requirements provided in this document ensure proper installation and operation of the Stratasys J750/J700 3D printing system. The customer is responsible for preparing the site as described in this document, and according to any applicable local regulations.

If you have any questions about the information in this document, contact your Stratasys representative.

All site requirements must be met before the installation date. The Site Preparation Checklist should be submitted to your Stratasys representative. Shipping will be arranged after the checklist is received by Stratasys.

Non-compliance with requirements specified in this document may result in additional installation charges.

## Installation and Training Schedule

- Basic installation and adjustment: 2 work days
- Operator training (operation and maintenance): 2 work days
- Product designer training (advanced features and work flow): ½ work day
- Practice under supervision: 1½ work days

# Physical Description

The Stratasys J750/J700 3D printing system consists of the following main components:

- printer
- printer computer (built into the printer)
- printer-server workstation

Figure 1 Stratasys J750/J700 printer



## Size and Weight

Table 1 Size and weight

Unit	W × H × D (cm)	W × H × D (inch)	Weight kg (lb)
Printer	140 × 126 × 110	55.1 × 49.6 × 43.3	430 kg / 948 lb
Materials cabinet	67 × 117 × 64	26.4 × 46.1 × 25.2	152 kg / 335 lb



W = Width; H = Height; D = Depth

# Shipment and Delivery

## Shipping Information and Customer Responsibility

Shipment to the customer will be arranged by a Stratasys distributor as indicated in the “ship to” part of the invoice. The customer is responsible for providing detailed delivery information, including, whether or not there is loading dock at the delivery site.

The customer is responsible for transporting the printer to a suitable installation site, and for unloading, unpacking, and moving it to its final location. Upon request, your Stratasys service provider will advise regarding these matters.



**Note:**

Only Stratasys-certified Customer Support Engineers are authorized to unpack and install equipment supplied.

## Shipping Pallet

The following table shows the approximate size and weight of the printing system mounted on a pallet.

Table 2 Size and weight of printer on shipping pallet

	W × H × D (cm)	W × H × D (inch)	Weight (kg/lb)
Printer	161 × 159 × 161	63.4 × 62.6 × 63.4	750 / 1654
Materials cabinet	109 × 139 × 94	42.7 × 54.7 × 37	300 / 661



W = Width; H = Height; D = Depth

## Lifting Equipment

A forklift or hand-operated pallet truck with the following specifications is required:

- lifting capacity: 800 kg (1650 lb)
- extension: 150 cm (60 in.)

## Unloading

The unloading area should be a level surface.

An area of 10 m<sup>2</sup> (108 sq ft) is required for the forklift to remove the printer from the delivery truck.

A clearance of 120 cm (4 ft) around the back and sides of the packaging is required for unpacking the printer.

A clearance of 390 cm (13 ft) from the front is required for unloading the printer from the pallet.

The installation location must be accessible from the unloading area. The customer is responsible for unloading the printer from the truck and transferring it to the installation location. Minimum space requirements for unloading the printer are shown in the figure below.

Figure 2 Unloading dimensions—top view

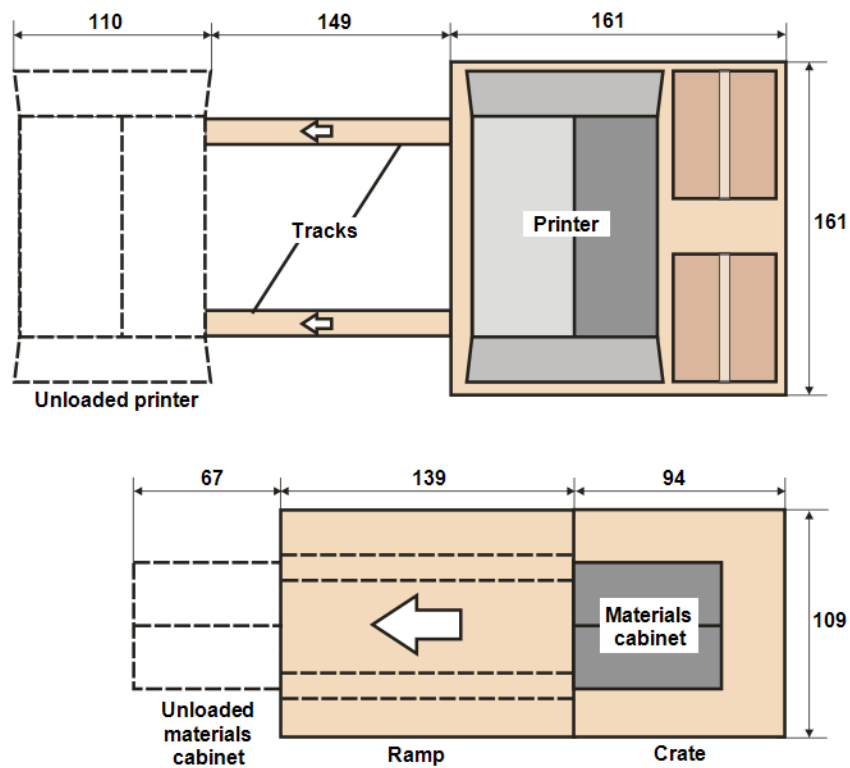

**Note:**

Dimensions are shown in centimeters.



## Installation Area

The installation area should be free of sources of vibration and electromagnetic interference that could affect the proper functioning of the printer.

The floor gradient should be less than 0.5% (5 mm per meter).

The floor should be stable and able to bear the load of the printer. The minimum floor load is 607 kg/m<sup>2</sup> (125 lb/ft<sup>2</sup>).

The server workstation and the printer should be located in the same room.

The cable between the server workstation and the printer should not exceed 5 meters (16 feet). The communication cable provided should not be extended or replaced with a longer cable.

Clearance around and above the printer should ensure convenient access and servicing.

The area around the printer should remain dry at all times. Do not place the cleaning station within 5 meters (16 feet) of the printer.

Shelves and cabinets are recommended near the printer for convenient storage of tools, parts, accessories, manuals, and materials.

## Floor Plan (Printer Area)

The following is a sample floor plan, showing the 3D printing system—the printer and the materials cabinet. The dimensions shown in the figure are the minimum clearance requirements.

Figure 3 Printer floor plan (sample, not to scale)

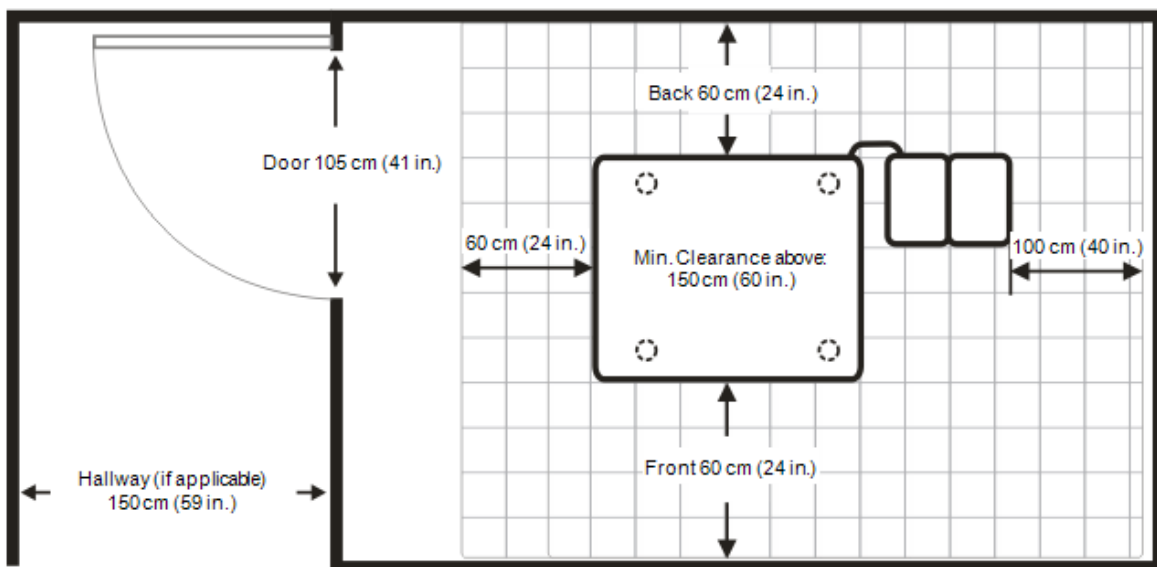

# Workstation Requirements

The customer is responsible for supplying a computer with the following specifications for any workstation that connects to the printer.

The customer is responsible for supplying any client computer that connects to the printer. To view the specifications, [click here](#), or browse to: <http://help.grabcad.com/print/system-requirements>.

Make sure that the server workstation is set up with Administrator privileges.

# Electrical Requirements

The customer is responsible for ensuring that all tasks described in this section are performed by qualified personnel.

## Power

A stable, reliable source of power is required. Power to the UPS (or printer) should be supplied directly from the main electrical panel. Other electrical outlets should not be connected to the line.

Printer power rating:

- 100–120 VAC, 50–60 Hz, 13.5 A , 1 phase
- 220–240 VAC, 50–60 Hz, 7 A , 1 phase

Printer short circuit rating: 1000 A

If the power at the facility does not support the above specifications, contact your Stratasys specialist.

**Important:**

The diagram below shows the required connection to the power socket. Make sure that the electrician sees this before installing the printer.

Figure 4 Connection diagram

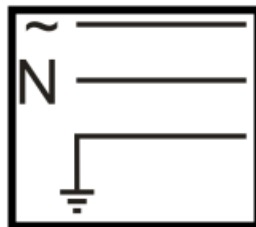

## Grounding

The printer is grounded through a single-phase, AC plug. Make sure that the AC outlet is properly grounded, in accordance with local electrical codes.

## Circuit Breaker

A Type-C circuit breaker with the following specification is required on the power line (subject to the local electrical code).

Table 3 Circuit breaker

Voltage	Circuit Breaker
100–120 VAC	15 A or 16 A
220-240 VAC	10 A

## Residual Current Device (RCD)

The wall outlet must be connected to a residual current device (RCD).

## Power Connection

The following power cables are supplied with the printer:

- one 220-VAC cable  
The customer must provide a suitable plug and have it connected by an electrician.
- one 110-VAC cable with a plug

The following electrical outlets are required:

- one outlet behind the printer
- three outlets close to the printer (for the workstation, monitor, and servicing equipment)

## UPS (Uninterrupted Power Supply)

It is recommended that the printer is powered through a UPS unit, provided by the customer. If installed, the UPS ensures that—

- the quality of printing is not affected by power fluctuations from the mains.
- the printer computers can perform a “graceful shutdown” in the event of a power failure.

The UPS specifications are listed below.

Table 4 UPS requirements

Voltage <sup>1</sup>	Current	Power	Power Factor <sup>2</sup>	Bridging Time	Interface
100–120 VAC	16 Amps	1500 VA	0.9	15 minutes	USB port <sup>3</sup>
220–240 VAC	8 Amps				Compatible with Windows® 7
					Command-line control <sup>4</sup>

The third-party Eaton PW9130G3000T UPS has been tested at Stratasys and has been found to meet the above requirements.

---

<sup>1</sup>Single-phase; 50/60 Hz

<sup>2</sup>Defined as the input-to-output ratio of the UPS.

<sup>3</sup>UPS units that only connect to a serial communication port are not suitable.

<sup>4</sup>Command-line control is necessary for the UPS software to execute a script in the printer software when shutting down.

# Communication Lines

## Local Area Network

A LAN communication cable is required if client workstations are connected to a local network, as shown in the following diagram.

Figure 5 Network installation

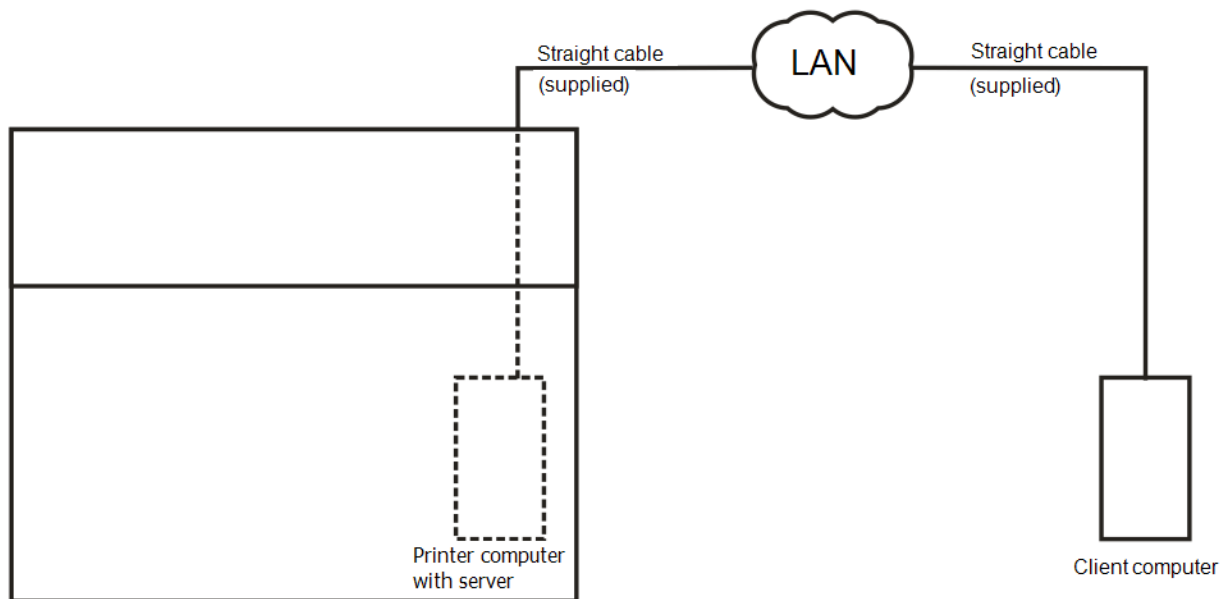

The connection to the local network should be established *prior to* printer installation.

The customer is responsible for ensuring that the client computer can connect to the printer via the LAN, at [http://\[printer IP address\]:80](http://[printer IP address]:80).

If the IP address is dynamically configured, a static IP address must be assigned by the network administrator.

## Telephone

A telephone near the printer is recommended for general communication and service calls.

# Environmental Conditions

## Temperature and Humidity

The temperature and relative humidity around the printer must be maintained within certain limits. Peak conditions occur when the printer and the server workstation draw maximum electrical power, resulting in the heat dissipation listed in the table below.

Table 5 Heat dissipation (peak conditions)

	Heat Dissipation
Printer	1500 W (5140 BTU/hr)
Server workstation	450 W (1530 BTU/hr)
Total	1950 W (6670 BTU/hr)

The room temperature and relative humidity should not exceed the limits listed in the table below.

Table 6 Room temperature and relative humidity specifications

	Range
Temperature	18°C to 25°C (64.5°F to 77°F)
Relative humidity	30%–70% non-condensing

## Air Quality

To ensure optimal air quality around the printer, a connection to an external ventilation duct is recommended (see "Accessories and Utilities" on the next page). Otherwise, the room ventilation system should change the air at least four times every hour.

## Noise Level

The noise level around the printer is typically less than 65 dB during printing.

# Accessories and Utilities

## Start-Up Kit

The printer is supplied with a start-up kit, which includes tools and accessories. These tools and accessories should be available during printer installation and operation.

## Exhaust Adapter

An exhaust adapter is supplied with the printer. When attached to the back of the printer and connected to an external ventilation fan with a duct, air expelled from the printer is discharged directly outdoors, as shown in the figure below.

Duct Diameter	Required Suction at the Exhaust Adapter	
	Minimum	Maximum
6 in (150 mm)	212 cfm (6 m <sup>3</sup> /min)	269 cfm (7.6 m <sup>3</sup> /min)

Figure 6 Printer exhaust system

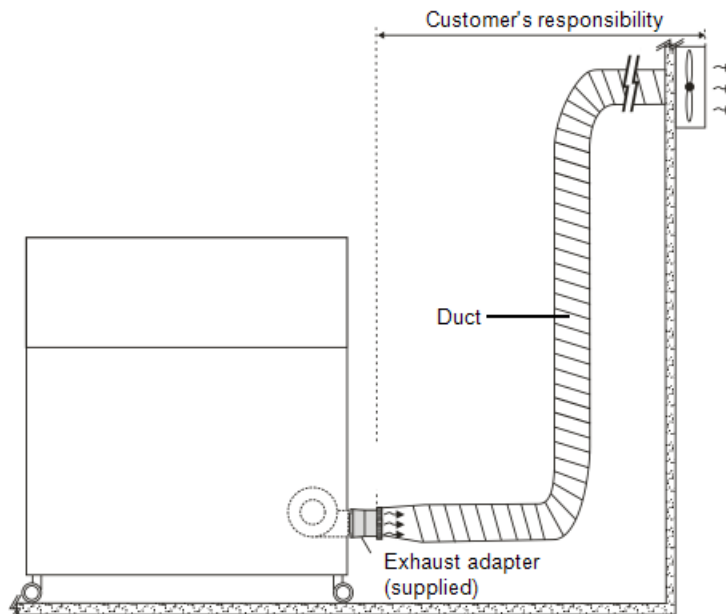

## Eyewash Station

It is recommended to install an eyewash station near the printer, for emergency use.



## Compressed Air

Compressed air is useful for routine cleaning and maintenance activities. If a compressed air line is available at the site, it is recommended (but not required) that an outlet be installed near the printer.

**Note:**

If the compressed air line does not include an air-dryer unit, a water/oil trap must be installed on the air gun used for cleaning the printer. The recommended air pressure is 5-7 bar (70-90 PSI).

## Fire Safety Equipment

A gas-based fire extinguisher is recommended in case of fire in or near the system. Some other fire extinguishers are also acceptable, but liquid fire extinguishers should not be used. (Contact local fire authorities for specific recommendations.)

# Materials Handling and Storage

## Printing Materials

Printing materials should be stored indoors, in a dry area with adequate ventilation. The following table lists general requirements for transport, storage, inventory control, and disposal.

Table 7 Requirements for hazardous materials

Topic	Requirement
Storage	15°C to 27°C (59°F to 81°F)
Inventory control method	First In First Out (FIFO)
Disposal	In compliance with local regulations

These specifications are applicable for most printing materials. Requirements for handling and storing specific materials appear in the Material Safety Datasheet (MSDS) included with each material.



**Note:**

- Non-compliance with these recommendations might result in reduced shelf life.
- Disposal of all liquid and solid waste, cleaning cloths, gloves, and empty material containers must be done in accordance with local laws and regulations.

## Cleaning Solvent

One liter of isopropanol (IPA) or ethanol (ethyl alcohol) should be available at all times for cleaning purposes.

The customer is responsible for ensuring that the material storage area complies with local regulations.

# Site Preparation Checklist

A checklist is provided by your Stratasys representative listing all of the tasks described in this document.

Fill in the information requested in the checklist, and submit it to your Stratasys representative. An installation date will be scheduled after the checklist has been approved by Stratasys.



[www.stratasys.com](http://www.stratasys.com)

---

#### HEADQUARTERS

7665 Commerce Way, Eden Prairie, MN 55344

+1 888 480 3548 (US Toll Free)

+1 952 937 3000 (Intl)

+1 952 937 0070 (Fax)

2 Holtzman St., Science Park, PO Box 3496

Rehovot 76124, Israel

+972 74 745 4000

+972 74 745 5000 (Fax)

# stratasys®

THE 3D PRINTING SOLUTIONS COMPANY

ISO 9001:2008 Certified

©2017 Stratasys Ltd. All rights reserved. Stratasys, Stratasys logo, PolyJet, Objet, Objet24, Objet30, Objet30 Pro, Objet30 Prime, Eden, Objet Eden260V, Objet Eden260VS, Objet Eden350V, Objet Eden500V, Connex, Objet260 Connex1, Objet260 Connex2, Objet260 Connex3, Objet350 Connex1, Objet350 Connex2, Objet350 Connex3, Objet500 Connex1, Objet500 Connex2, Objet500 Connex3, Durus, Endur, Vero, VeroBlue, VeroBlackPlus, VeroClear, VeroCyan, VeroDent, VeroDentPlus, VeroGlaze, VeroGray, VeroMagenta, VeroWhitePlus, VeroYellow, Tango, TangoBlack, TangoBlackPlus, TangoGray, TangoPlus, Digital ABS and Digital ABS2 are trademarks or registered trademarks of Stratasys Inc., registered in the United States and other countries. ULTEM is a registered trademark of SABIC or affiliates. All other trademarks belong to their respective owners. Product specifications subject to change without notice. For more information about Stratasys systems, materials and applications, call 888.480.3548 or visit [www.stratasys.com](http://www.stratasys.com)